

J. HARLEY.  
HOLLOW MANDREL LATHE.

No. 559,578.

Patented May 5, 1896.

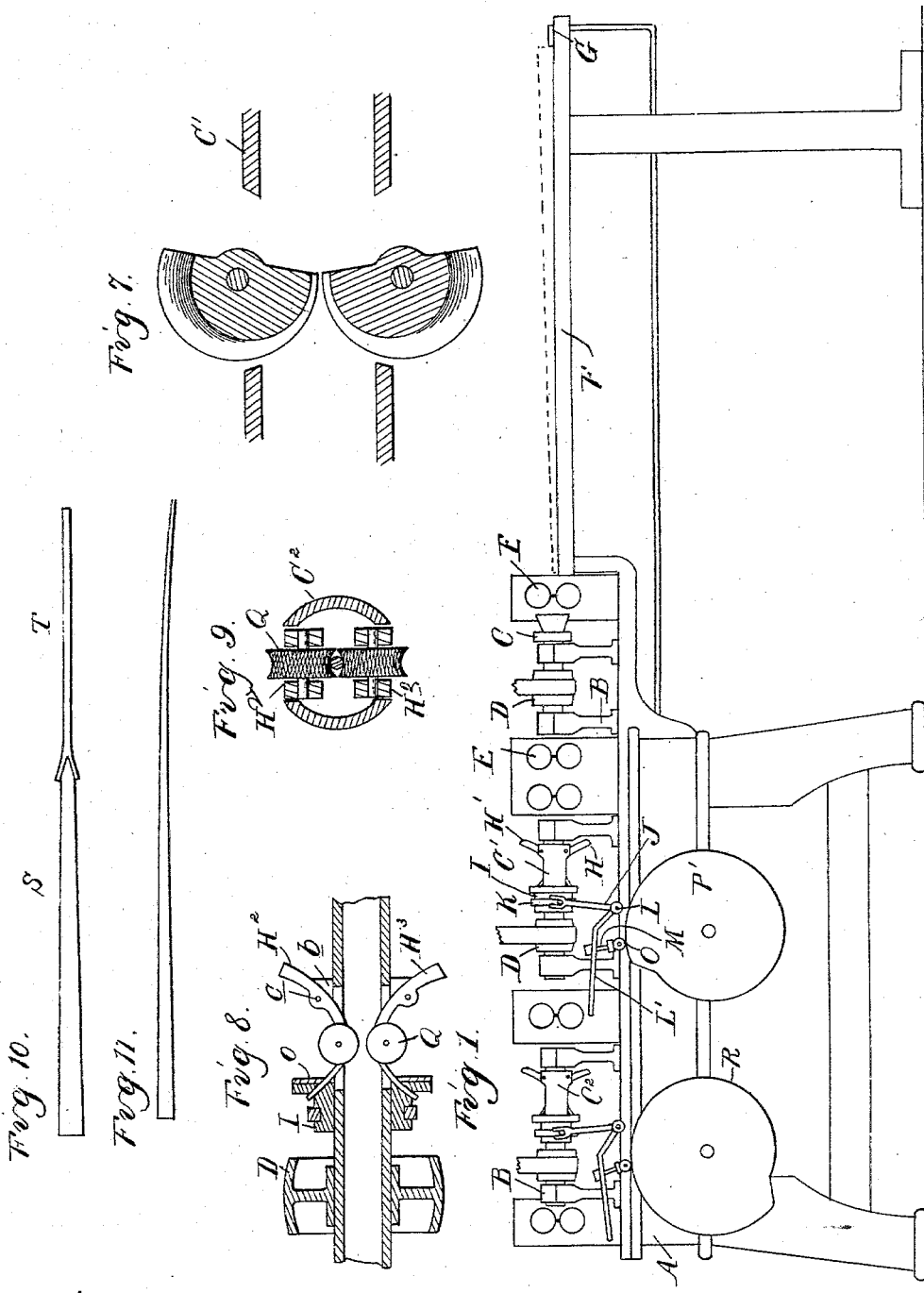

Witnesses  
*A. L. Hobby*  
*A. F. Baugh*

Inventor  
*John Harley*  
 By *Wm. S. Ingham* Atty.

(No Model.)

2 Sheets—Sheet 2.

J. HARLEY.  
HOLLOW MANDREL LATHE.

No. 559,578.

Patented May 5, 1896.

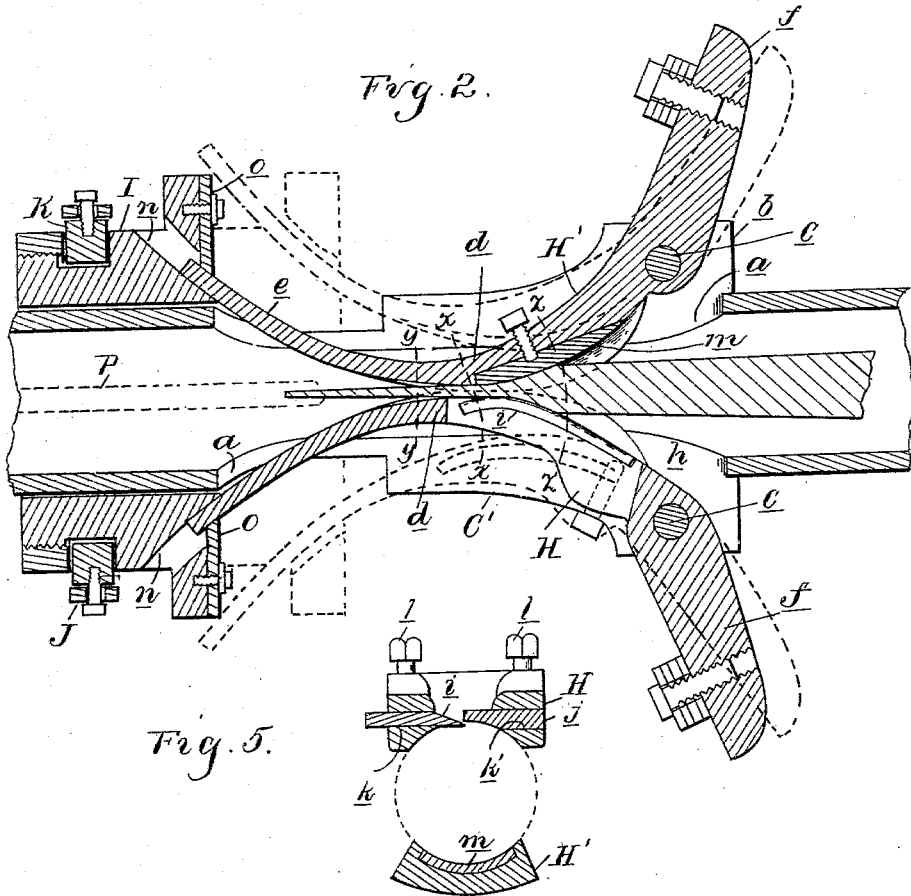
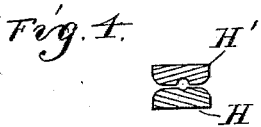
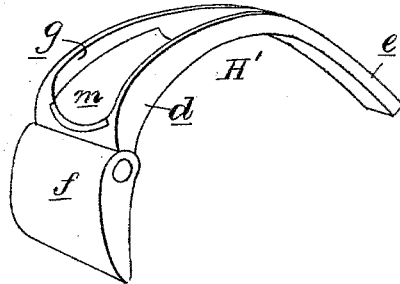
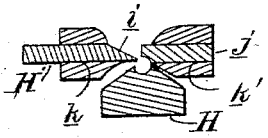

Fig. 2.

Fig. 5.

Fig. 3.

Fig. 6.



Witnesses  
 A. L. Hobby  
 O. F. Barchet

Inventor  
 John Harley  
 By Messrs. Sprague & Co.  
 Attys.

# UNITED STATES PATENT OFFICE.

JOHN HARLEY, OF DETROIT, MICHIGAN.

## HOLLOW-MANDREL LATHE.

SPECIFICATION forming part of Letters Patent No. 559,578, dated May 5, 1896.

Application filed April 1, 1895. Serial No. 543,984. (No model.)

*To all whom it may concern:*

Be it known that I, JOHN HARLEY, a citizen of the United States, residing at Detroit, in the county of Wayne and State of Michigan, have invented certain new and useful Improvements in Hollow-Mandrel Lathes, of which the following is a specification, reference being had therein to the accompanying drawings.

My invention relates more specifically to a hollow-mandrel lathe adapted for either turning or re-turning small and flexible rods, and is especially designed for the manufacture of whips.

The invention consists in the means employed for guiding the work while operated upon by the cutter, and, further, in the peculiar construction, arrangement, and combination of parts.

In the drawings, Figure 1 is a diagram elevation of my lathe. Fig. 2 is a longitudinal section through one of the mandrels showing the guide-jaws. Fig. 3 is a cross-section on line *xx*, Fig. 2. Fig. 4 is a cross-section on line *yy*, Fig. 2. Fig. 5 is a cross-section on line *zz*, Fig. 2, showing the jaws in a different position. Fig. 6 is a detached perspective view of one of the jaws. Fig. 7 shows a modification. Fig. 8 is a longitudinal section through the mandrel carrying the finishing-cutter. Fig. 9 is a cross-section therethrough. Fig. 10 is an elevation of a whip-blank, and Fig. 11 is an elevation of the finished whip.

A is the bed or frame of the machine, upon which are journaled in suitable bearings B one or more hollow mandrels C, C', and C<sup>2</sup>, preferably three in number. These mandrels are arranged in axial line with each other and each is provided with a drive-pulley D.

E are self-centering feed-rolls arranged in front and rear of each mandrel.

F is a feed-table, and G is a pusher or starter bar, adapted to be intermittently operated to feed a blank from the table F into engagement with the feed-rolls.

The mechanism for imparting motion to the feed-rolls and starter-bar may be of any suitable construction, and I have therefore omitted showing it in the drawings.

The hollow mandrel C carries the roughing-cutter, adapted to round up the square portion of the blank. The mandrel C' carries

the shaping-cutter and the mandrel C<sup>2</sup> the finishing-cutter, which I will now describe in detail.

The mandrel C' is provided on opposite sides with the apertures *a*, in which are arranged the curved or substantially loon-shaped guide-jaws H and H', adapted to be moved correspondingly toward or from the axis of the mandrel. Both jaws are grooved so as to embrace the work, and the jaw H preferably carries the knife or cutter.

In the drawings I have shown the jaws H and H' pivoted to the mandrel between the lugs *b* thereon by means of the pivot-pin *c* and operated by a sleeve I, longitudinally slidingly secured to the mandrel. Each jaw comprises the guide portion *d*, the actuating-arm *e*, and the counterweight portion *f*. The portion *d* is provided with a longitudinally-tapered grooved bearing-surface *g*, of such a form that as the jaw is swung upon its pivot toward or from the axis of the mandrel it will at all times present a concave bearing-surface to the work, the radius of the curve of which is substantially its distance from the axis.

The jaw H forms a shave, which is centrally apertured at *h*, and projecting into this aperture from opposite sides are the bit or shave-knife *i* and the wear-plate *j*, secured, respectively, in slots *k* *k'* in the jaw by the set-screw *l*. Both knife and wear-plate are curved to conform to the shape of the jaw, and the former may be set to take up any desired cut. The jaw H' is also preferably provided with an adjustable wear-plate *m*.

The arms *e* pass out through the slot *a* in the mandrel, being inclined to the axis thereof, and engage with suitable bearings on the sleeve I, such as the inclines *n* and adjustable plates *o*. The sleeve is revolved with the mandrel by the feather *p* and is moved longitudinally by the rock-arm J engaging with the collar K.

I is a rock-shaft carrying the arm L'. M is the actuating-arm provided with an anti-friction-roll O, adapted to rest on the cam P', which latter is driven by suitable connection (not shown) with the feed mechanism and is properly timed therewith.

The construction of the parts carried by the mandrel C<sup>2</sup> may be the same as the mandrel C' if the lathe is to be used for turning

wood only, the knife being set to take a finer cut; but where the machine is used for turning whips having whalebone cores I employ the construction shown in Figs. 8 and 9, in which the jaws H<sup>2</sup> and H<sup>3</sup> carry grooved cutter-wheels Q, the periphery of each being roughened or file cut. The movement of these jaws is governed by a cam R and intervening mechanism similar in construction to the cam P.

In practice the operation of the machine is as follows: When the lathe is used for turning whips, the blanks, generally composed of a wooden handle-section S and a reed-section T, glued together, as shown in Fig. 10, are piled upon the table F and one at a time are placed by the operator in front of the starter G. This at the proper time pushes the blank into engagement with the feed-rolls, which carry it through the mandrels. In passing through the mandrel C the square portion of the blank is rounded up. Upon entering the mandrel C' the mechanism is so timed that the jaws H and H' are in their most position and present a funnel-shaped bearing-surface to the end of the blank, which is reduced in size by the shave-knife i to a diameter equal to the smallest distance between the jaws. As the blank is fed on, the jaws open out, and in so doing present a constantly enlarging or expanding bearing-surface to the work, holding it from lateral displacement while operated upon by the knife and producing a conical or tapered rod, as shown in Fig. 11.

One of the leading features of my lathe is that with it I am enabled to turn from tapered stock or return rods of varying diameter—such as fork-handles, &c. This, so far as I am aware, has never been successfully accomplished by hollow-mandrel lathes heretofore used, for the reason that only the largest part of the rod can be guided or supported while operated upon by the cutter; but my construction is provided with what may be termed an "expansible" and "contractible" guide, which closes in and opens out correspondingly to the movement of the cutter-arm and at all times embraces the work.

I have found by actual use of my lathe that I am enabled to turn flexible rods to less than one-sixteenth of an inch in diameter and taper them from that to one inch or more in size.

While I have shown and described two oppositely-arranged guide-jaws, I do not wish to be limited to this precise construction, as a single guide-jaw of my construction either carrying the cutter or moving correspondingly toward or from the axis of the mandrel may be sufficient for a certain class of work. The two jaws, however, I deem to be the preferable construction.

What I claim as my invention is—

1. The combination with a hollow mandrel having longitudinal slots therein, of a curved guide-jaw carried by said mandrel, and work-

ing in one of the said slots, a cutter carried by the mandrel and working in the other slot, and means adapted to move said guide-jaw and cutter correspondingly toward or from the axis of the mandrel, substantially as described.

2. The combination with a hollow mandrel of a guide-jaw pivoted to said mandrel provided with an eccentric taper-grooved bearing-surface, a cutter carried by the mandrel, and means for moving said guide and cutter toward and from the axis of the mandrel, substantially as described.

3. The combination with a hollow mandrel having oppositely-arranged slots therein, curved guide-jaws carried by said mandrel and adapted to be moved in said slots correspondingly toward or from the axis of the mandrel, and a cutter carried by one of said guide-jaws, substantially as described.

4. The combination with a hollow mandrel of a shave pivotally mounted on said mandrel, said shave comprising a guide-jaw curved longitudinally of the mandrel and grooved transversely of the axis of the mandrel, and a bit or knife, and means for moving said shave in the plane of and toward and from the axis of the mandrel, substantially as described.

5. The combination with a hollow mandrel of a shave pivotally mounted on said mandrel, comprising a guide-jaw curved longitudinally of the mandrel and grooved transversely of the axis of the mandrel, a bit or knife, and a wear-plate adjustably secured to said jaw, and means for moving said shave in the plane of and toward and from the axis of the mandrel, substantially as described.

6. The combination with a hollow mandrel of a shave carried by said mandrel comprising a pivoted guide-jaw having an eccentric curved taper-grooved surface, a bit or knife and a wear-plate conforming to the curve of the jaw and adjustably secured thereto.

7. The combination with a hollow mandrel of a guide-jaw pivoted to said mandrel and comprising an inwardly-bowed arm on one side of the pivot, forming the guide-surface and actuating-arm, and a counterweight-arm on the other side of the pivot.

8. In a lathe, the combination of the hollow mandrel carrying cutters, a finishing-mandrel in line therewith, oppositely-arranged jaws carried by said last-named mandrel curved in a longitudinal plane passing through the axis of the mandrel, grooved cutter-wheels on said jaws, and means for moving said jaws correspondingly toward and from the axis of the mandrel, substantially as described.

In testimony whereof I affix my signature in presence of two witnesses.

JOHN HARLEY.

Witnesses:

M. B. O'DOHERTY,  
O. F. BARTHEL.